

BR-600V Series Handrail

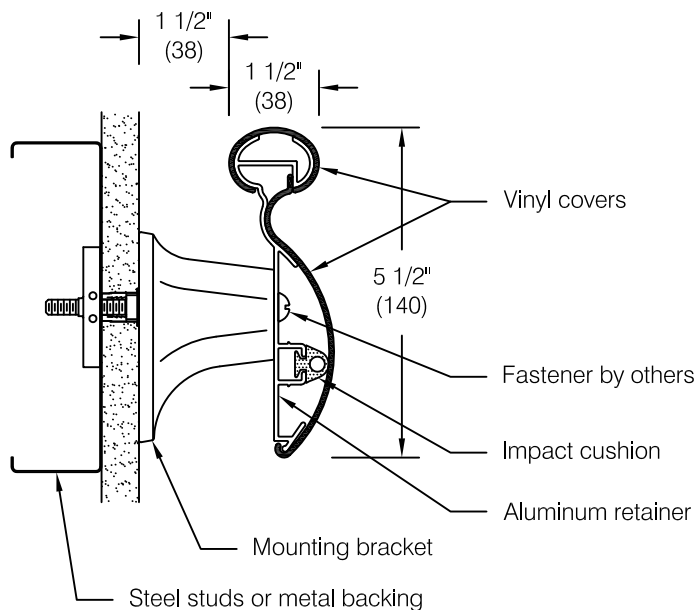

This installation instruction is applicable to:

BR-600V

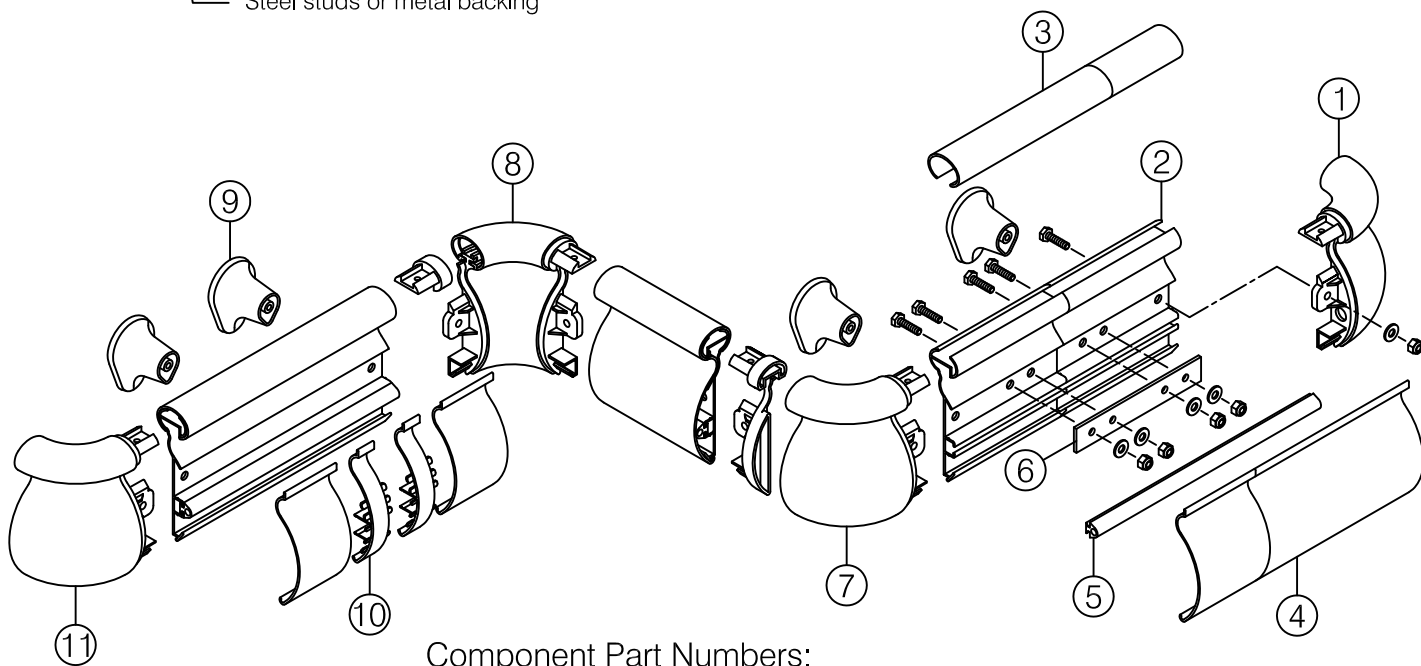

Component Part Numbers:

- 1.) BRR-625V right return
- 2.) BRA-600V aluminum retainer
- 3.) BRTV-600 top vinyl cover
- 4.) BRBV-600 base vinyl cover
- 5.) B-100 impact cushion
- 6.) SPL-600 splice
- 7.) OBR-650V outside corner
- 8.) IBR-675V inside corner
- 9.) BR-108 bracket
- 10.) ACC-600 vertical accent (optional)
- 11.) BRL-625V left return

- Step 1:** Determine top of handrail and snap a chalk line 3" below for centerline of mounting hardware, see **fig 1**.
- Important:** Store material in a clean dry place where the temperature is maintained above 50°F (10°C). Walls and rooms should be maintained at a minimum of 65°F (18°C) for at least 48 hours prior to installation. Acclimate materials to normal building conditions for at least 24 hours before cutting and installing.
- Step 2:** Cut aluminum retainer. See **Cutting Adjustment Diagrams and Schedule** for adjustments to aluminum retainer length at wall returns, inside corners, and outside corners. Refer to **Minimum Layout Configurations** for additional information.
- Important:** All cuts must be square and deburred
- Step 3:** Layout aluminum retainer "face up", mark and drill bracket mounting hole locations.
- Bracket mounting holes must be spaced:**
- Not to exceed 32" on center
 - 1 1/2" to 6" from end of aluminum retainer at returns and corner accessories
 - A minimum of 4" from end of retainer at splices to avoid interference with splice hardware (shown in **fig 9**)
 - To align with horizontal metal backer plate or metal studs (by others)
- Note:* Use groove in retainer to locate centerline for drilling, see **fig 2**
- Step 4:** Locate and drill bracket mounting holes in wall construction using the aluminum retainer as a template or by careful measurement. Choice of hardware will dictate hole diameter.
- Step 5:** Wall returns and corners are pre-assembled at the factory. If the friction fit assembly loosens during shipment, assemble wall returns by placing the groove in the handgrip mold over the raised "T" of the base mold with the open ends facing the same way, see **fig 3**. Rotate the two molds until the locking tab of the base mates with the receiver in the top, see **fig 4**. Use a similar technique to install the top on the base of an inside corner. Press fit inserts to form inside and outside corners as shown in **fig 5** and **fig 6**.
- Step 6:** Insert molded accessories into end of retainer, press firmly to ensure molded part is seated squarely against the retainer. Drill accessory mounting holes using the accessory as a template, see **fig 7**.
- Step 7:** Attach wall returns, outside corners and inside corners to retainer with accessory seated firmly and squarely while tightening. Fasten with 1/4" bolt, flat washer and nylon lock-nut provided.
- Caution:* Do not use a lock washer, use flat washers only. Always place a flat washer between nut and molded tab. Tighten to 10 ft-lbs maximum torque, see **fig 8**.
- Important:** For proper installation a portion of the molded accessory must extend into the aluminum retainer. Use caution at corner conditions to ensure accessory is seated properly at both connections to aluminum before both retainers are fastened to the wall construction.
- Step 8:** Mount assembly to wall with the appropriate hardware according to wall construction. See **step 9** for splicing information.
- Suggested hardware:**
- Drywall: Toggler® brand toggle bolts
 - Masonry: Plastic Alligator® insert
- Step 9:** Refer to **fig 9** for splicing of aluminum retainer as required on longer handrail lengths. Always locate splice joints a minimum of 4" from bracket locations. For best results offset butt joint in cover from splice in aluminum retainer.
- Step 10:** If optional ACC-600 vertical accents are being used snap fit them on aluminum retainer in locations desired. If accents are being used side-by-side slide them together after they are snapped in place so that the interlocking teeth pass under the next accent in sequence. The teeth will interlock properly only when all accents are aligned the same way, see **fig 10**.
- Step 11:** Measure between textured surfaces of wall returns, corner accessories, and vertical accents where used and cut vinyl covers to fit.
- Important:** All cuts must be square and deburred
- Step 12:** Install upper vinyl cover from the front back and then rotate into place while lifting upward to ensure cover is up as far as it will go, see **fig 11**. Install lower vinyl cover by inserting tab behind the installed upper cover and rotating into place until hook snaps over the lowest portion of the retainer see **fig 12**.

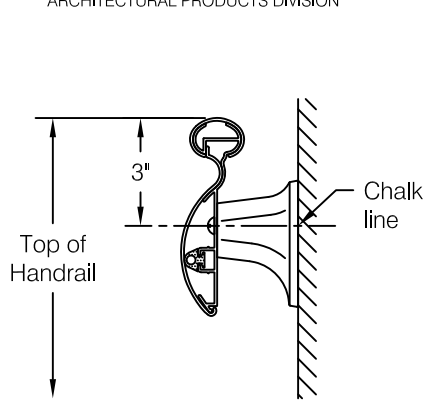

fig 1

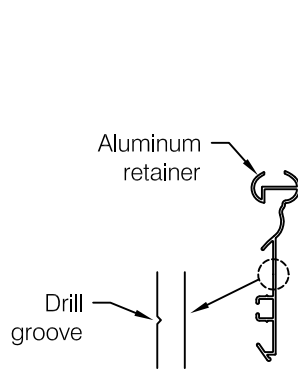

fig 2

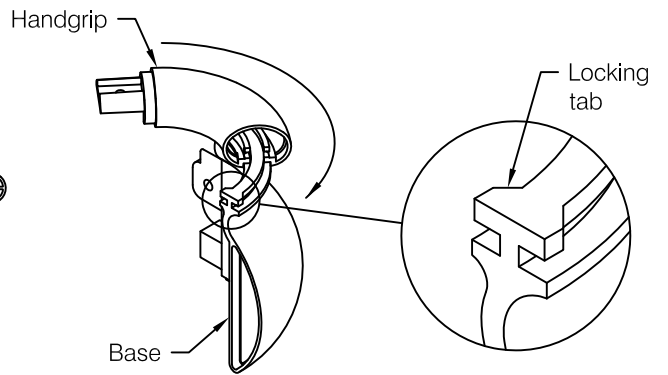

fig 3

fig 4

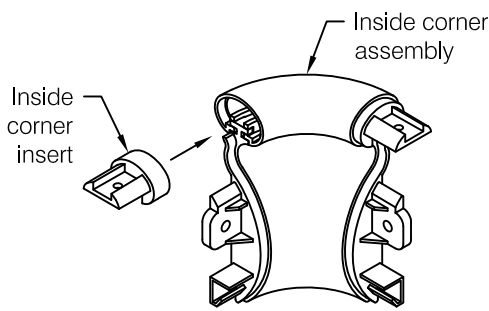

fig 5

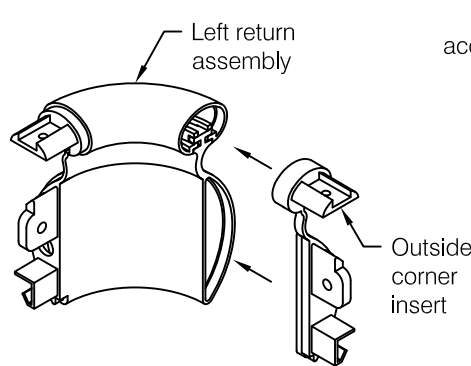

fig 6

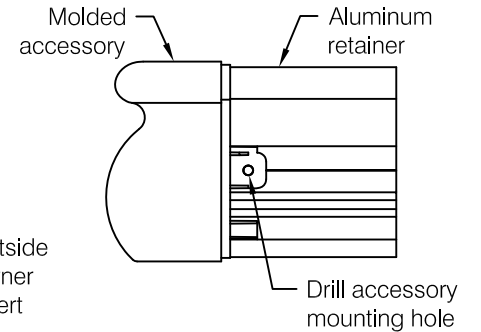

fig 7

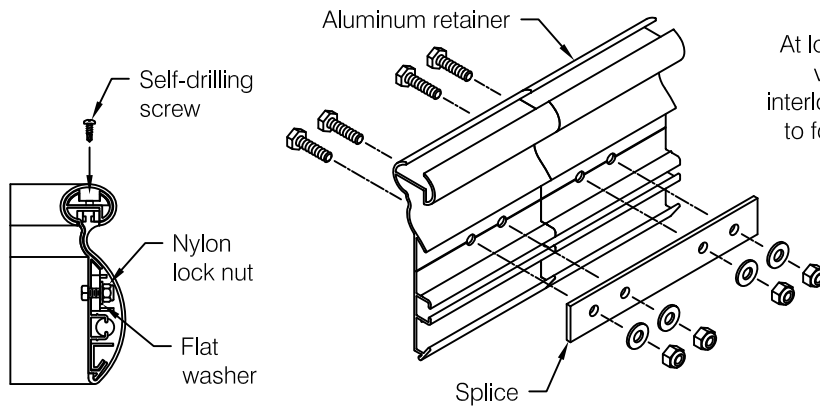

fig 8

fig 9

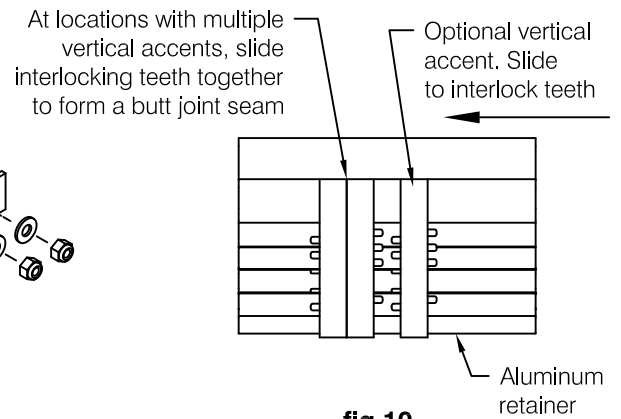

fig 10

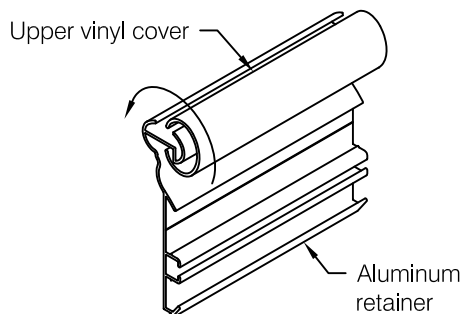

fig 11

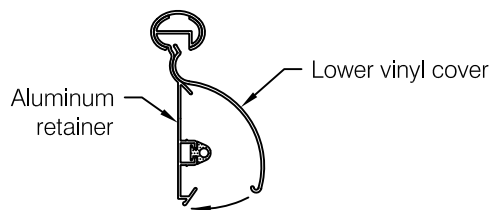
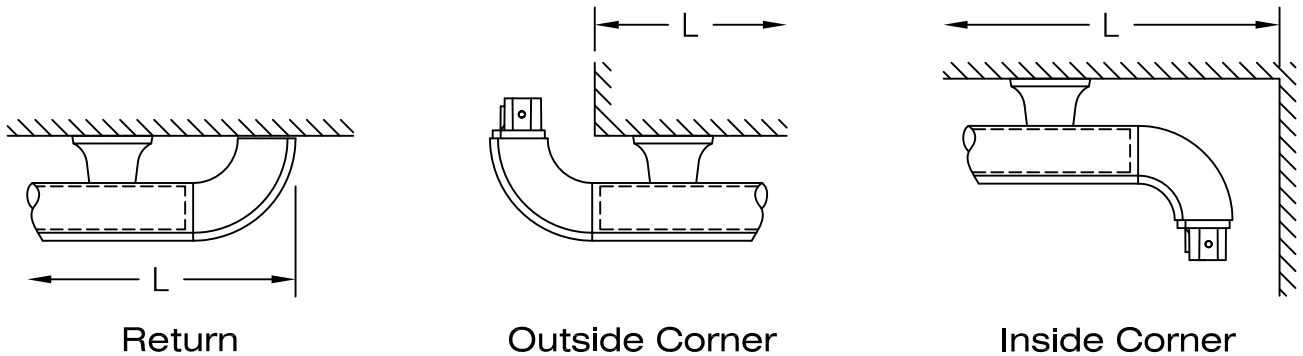

fig 12

Cutting Adjustment Diagrams and Schedule



	Aluminum Retainer	Vinyl Cover
Return	L - 3 7/16"	L - 3 3/16"
Outside Corner	L - 3/16"	L + 1/16"
Inside Corner	L - 4 11/16"	L - 4 7/16"

Important: install aluminum retainer and molded accessories before cutting the snap-on cover.

Minimum Layout Configurations

