

Installation Instructions

High Impact Corner Guards

Models: 150, 160, 170, 130, G2-150, G2-160, G2-170, G2-130

FIG. 1

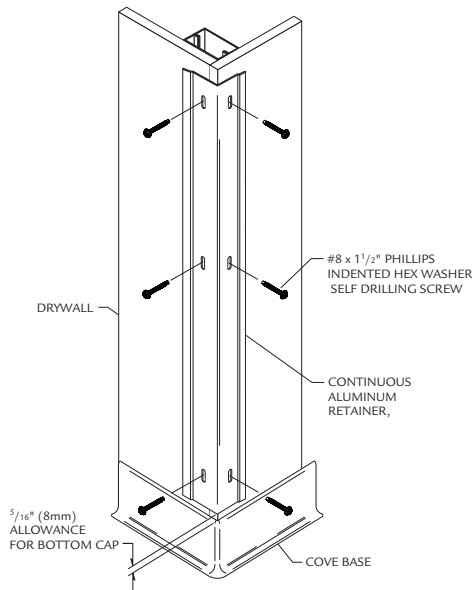

Please read all instructions before installing corner guards. Material must be stored, installed and used in environmentally controlled conditions.

1. Position aluminum retainer against wall, leaving allowance for bottom cap. Secure retainer to the wall using the pre-slotted holes on the retainer.

See Figure 1.

Note for concrete installation: Use the slotted tabs on the top and bottom caps to transfer and drill 1/4" (6.5mm) holes into the ends of the retainer. Transfer the location of all mounting holes to the wall. Drill marked holes on wall using a 1/4" drill bit and position Alligator anchors into holes. Mount retainer on wall with #10 x 1 3/4" phillips pan head screws and tighten to secure.

Note for 170 90° Bullnose Corner Guard: Corner bead of wall must be 3/4" (19mm) radius to accommodate retainer.

FIG. 2

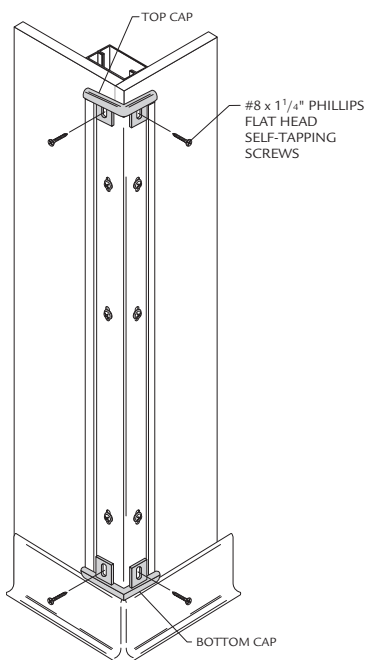

2. Overlap the retainer with the mounting tabs of the top and bottom caps and attach them to retainer. See Figure 2.

When installing flexible top caps on custom angle corner guards, use cup washers and flat head screws to fasten the top caps to the retainer. See Figure 2a.

Note for concrete installation: Overlap the retainer with the mounting tabs of the top and bottom caps and attach them to retainer and into the Alligator anchors using two, #8 x 1 1/2" phillips flat head screws per cap.

FIG. 2a

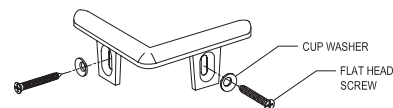

Installation Instructions

High Impact Corner Guards

Models: 150, 160, 170, 130, G2-150, G2-160, G2-170, G2-130

FIG. 3

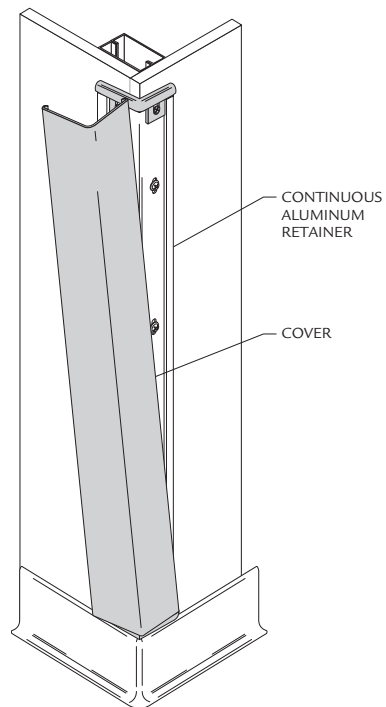

3. Position cover on retainer and adjust the top cap for a tight fit. Starting at the top, push cover onto retainer pressing over the entire length until it snaps into place. See Figure 3.