

Installation Instructions

Palladium® Rigid Vinyl Beadboard, Palladium® G2 Beadboard

FIG. 1

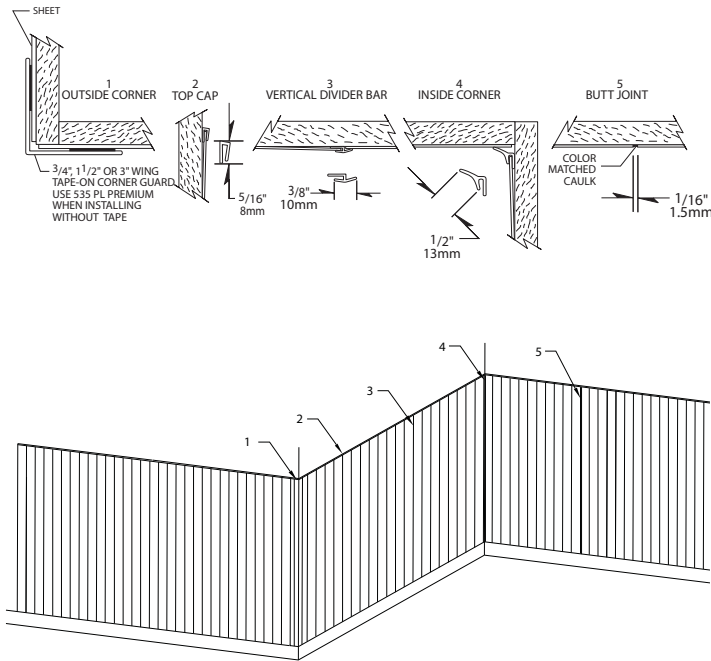
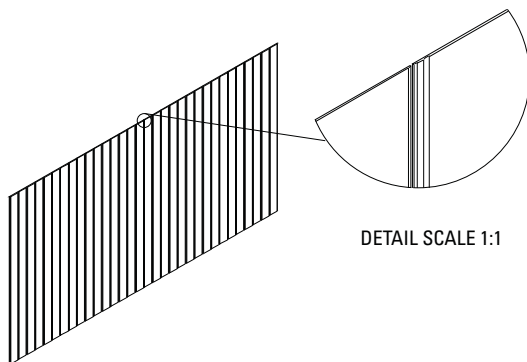

FIG. 2



Please read all instructions before installing Palladium® Rigid Beadboard Sheet. (see rigid sheet installation instructions for complete installation steps and precautions)

1. Before installation:

- a. Acclimate sheet, trim accessories, adhesives and wall substrates to room temperature 24 hours before installation
 - b. Allow sheet to lie flat 24 hours before installation
 - c. 24 hours before, during and 48 hours after installation, maintain a building temperature between 70-80 F and keep humidity below 80%
 - d. Substrate must be dry, well sealed and free of dirt, loose paint, wax and grease. Glossy surfaces may require sanding or priming to help promote adhesion.
 - e. Remove any coatings designed to improve clean-up as these coatings may affect adhesion.
 - f. InPro Bond or XT-2000+ adhesives can be used to apply sheet to securely adhered vinyl wallcovering. Adhering sheet over existing sheet or VWC will increase smoke generation, flame spread, and negate the UL Class A fire rating. If you choose to do this, follow the non-porous installation instructions that accompany InPro Bond and XT-2000+ adhesives.
 - g. Top caps, vertical divider bars and inside corners need to be slid on the sheet before applying adhesives.
- NOTE: When using Stainless Steel trim pieces cut with power miter box or similar.
- h. Handle beadboard sheet carefully. To avoid damage DO NOT roll or fold beadboard sheet.

2. FASTBOND 30 CONTACT CEMENT INSTALLATION (see container for complete instructions and precautions)

- a. Apply contact cement with brush or roller to the sheet, trim accessories and wall. Let the contact cement dry completely.
- b. After contact cement is dry, the installation must be completed within four hours. Properly position one end of the sheet on the wall. Continue aligning sheet until entire surface has contacted the wall. When a butt joint is used, leave a 1/16" gap between sheet to allow for expansion. See Figure 2.

IPC.469/REV.8

Installation Instructions

Palladium® Rigid Vinyl Beadboard, Palladium® G2 Beadboard

FIG. 3a

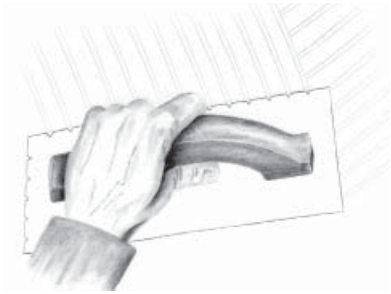
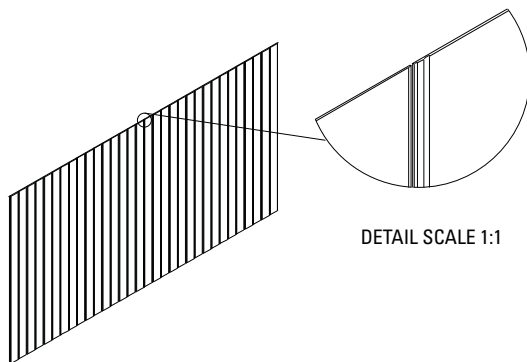

FIG. 3b



3. INPRO BOND ADHESIVE OR XT-2000+ ADHESIVE INSTALLATION (see rigid sheet installation instructions for complete installation steps and precautions)

a. Apply adhesive to the wall with trowel. Use a 1/8" x 1/8" V-notched trowel with 1/2" spaces between the V-grooves. If 1/8" V-notched trowel is not used, the yield of adhesive used may vary. See Figure 3a.

b. Position sheet on wall. Repositioning of the sheet can be done before rolling the sheet to the wall. When a butt joint is used, leave a 1/16" gap between vinyl to allow for expansion. See Figure 3b.

c. NOTE: Non-porous substrates that entrap water require longer drying times. When adhering sheet to metal, plastic laminate, glazed block, rigid plastic or vinyl wallpaper, allow adhesive to dry a minimum of 1 hour but not more than 3 hours. Adhesive should be firm to the touch and not transfer off the substrate before applying the sheet. When installing, keep material flat and properly aligned as you would with contact cement.

FIG. 4

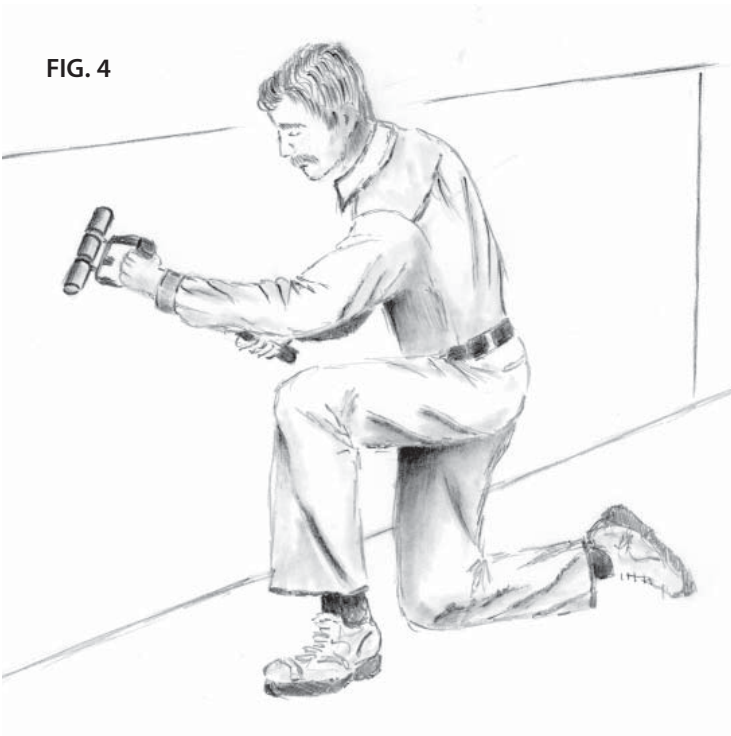

4. FOR ALL INSTALLATION METHODS - After sheet is on the wall, apply heavy body pressure to the sheet with an IPC extension roller. Roll entire surface. See Figure 4. Remove excess adhesive with methods and materials recommended by the adhesive manufacturer.

5. INSTALLATION OF COLOR MATCHED CAULK- Use color matched caulk to fill-in the joint between sheets. Apply masking tape along both edges of the joint. Cut the spout at a 45° angle and apply caulk directly to the joint. With a moistened finger or a putty knife, remove excess caulk from the joint. Remove masking tape and allow caulk to completely cure. If sinking occurs, reapply caulk following the steps listed above.

Installation Hotline • 866.EZINPRO

Inprocorp.com • 800.222.5556 • 262.679.9010

World Headquarters S80 W18766 Apollo Drive, Muskego, WI 53150 USA

IPC®

DOOR + WALL PROTECTION SYSTEMS
A DIVISION OF INPRO®