



Koffler Sales Company
Specialists in Floor and Wall Protection
For Over 50 Years!
1-888-355-6287

KOFFLER SALES COMPANY
785 Oakwood Road
Suite C-101
Lake Zurich, IL 60047-1524

ORDERING TIPS

Please provide the following information when ordering:

CASING

- If casing will be installed on its face or back, straight applications can be used as long as the radius is not very tight (less than 12").
- If the casing will be installed on its edge (true radius applications) it must be pre-curved in most cases (full circle, half circle, quarter circle, and arc eyebrows). Casing is generally bent with the thick edge to the outside of the radius, but can also be specified with the thick edge to the inside. When ordering, please note if the molding needs to be reversed, otherwise the thick edge will be on the outside.
- Casing for elliptical and oval applications must be pre-bent.
- Casing can also be used on the ceiling as an accent for crown molding, as panel molding, etc. If used as a crown molding accent, it must be pre-curved. Please specify if you are using a casing profile in a non-standard application so we can be sure to supply the correct item.



MEASURING STRAIGHT MOLDINGS

Straight (lineal, non-curved) profiles will only be suitable for certain applications. If you are unsure if a straight molding will work for you, please contact customer service before ordering.

To measure for straight applications, just measure the length needed and round up to the next even footage. For tight radiuses—order a pre-curved profile and specify whether it should be bent on the face or the back. This will ensure a snug fit.



To order, indicate profile, species and material length.

MEASURING PRE-CURVED TRUE RADIUS MOLDINGS

True radius moldings (full circles, half circles, quarter circles and arcs or eyebrows) do not need a template. Calculate the dimensions as shown below.

Note: There are limitations regarding how tight a radius can be created. The general "rule of thumb" is approximately 3 times the width of the profile.



Full Circles:

Diameter in inches x 4 =
Material Length (divide by
12 for feet)

To order, indicate profile,
species, diameter

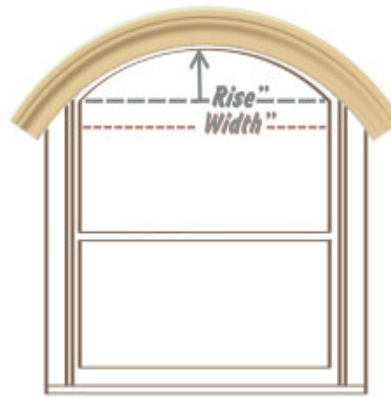

Arc or Eyebrows:

[Rise in inches x 3] +
[Width in inches] =
Material Length (divide
by 12 for feet)

A template is not
required if it is a true
radius opening.

To order, indicate
profile, species, rise and
width.

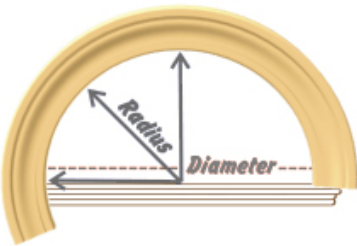

Half Circle:

Diameter in inches x 2 =
Material Length (divide by
12 for feet)

To order, indicate profile,
species, diameter



Quarter Circles:

Radius in inches x 2 = Material Length
(divide by 12 for feet)

To order, indicate profile, species,
radius

MEASURING CUSTOM PRE-CURVED MOLDINGS

Most custom shapes will require a template, such as casing for elliptical or oval openings. To create a template, refer to our [Template Guidelines](#).

Note: There are limitations regarding how tight a radius can be created. The general “rule of thumb” is approximately 3 times the width of the profile.

We have some standard templates available—just indicate the manufacturer of the window or door unit and the model number and we can confirm whether we have a template in stock.

Make sure the template fits exactly inside the radius edge. Calculate the dimensions as shown below, then round up to the next even footage to get the material length needed.



Ovals

[Rise in inches x 3] + [Width in inches] = Material Length (divide by 12 for feet)

To order, indicate profile, species and provide a template



Elliptical and Odd Radius Casings

[Rise in inches x 3] + [Width in inches] = Material Length (divide by 12 for feet)

To order, indicate profile, species and provide a template

Outside Radius Applications (OSR) – Convex

Measure the length of the straight edge (A). Find the center and place it against the curve of the wall until the left and right edges are equal distances from the wall.

Measure the distance from the corners of the straight edge to the wall (B).

Measure around the curve to get the wall length (C).

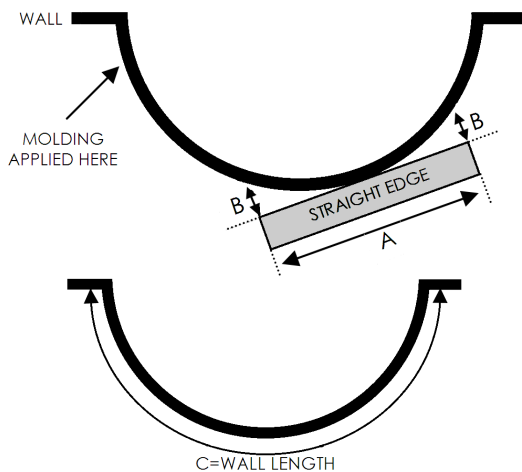

To order, indicate profile, species, straight edge length (A), distance from straight edge to wall (B), and wall length (C).

Inside Radius Applications (ISR) - Concave

Measure the length of the straight edge (A). Place it against the curve of the wall until the left and right sides touch the wall.

Measure the distance from the center of the straight edge to the wall (B).

Measure around the curve to get the wall length (C).

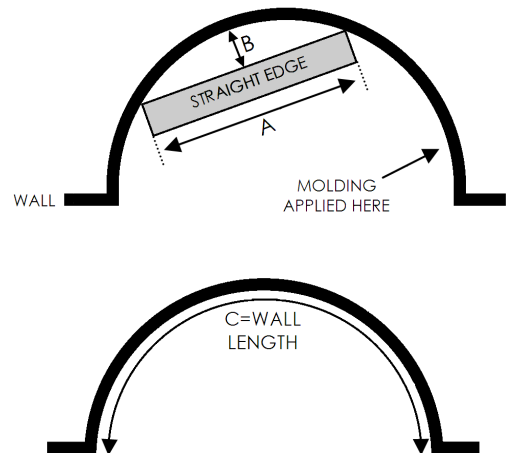

To order, indicate profile, species, straight edge length (A), distance from center of straight edge to wall (B), and wall length (C).

TEMPLATE GUIDELINES

Ovals, ellipses and compound radius curves require a template. Templates should be made of heavy plastic (easier to see opening below), construction paper, house wrap or tar paper. Make sure the template follows the contour of the curve exactly or imperfections will be duplicated in the molding shape.

Indicate which side of the molding faces the edge, and whether it is the inside or outside edge of the molding that will follow the line. Indicate if there is a reveal (the molding will be set back from the opening—usually about 1/4").

When measuring the material length, be sure to measure the outside edge of the molding and add an additional foot for mitering.

Mail the template to:

KOFFLER SALES COMPANY
785 Oakwood Road
Suite C-101
Lake Zurich, IL 60047-1524

Below is an example of the information to send to us:

PRODUCT INFO: Profile #: <i>WM356 Casing</i> Species: <i>Oak</i> Special Instructions: <i>1/4" Reveal</i>	CONTACT INFO: <i>Bill Smith</i> <i>100 South Main St.</i> <i>Anywhere, OH 12345</i> <i>555-555-5555</i>
---	--

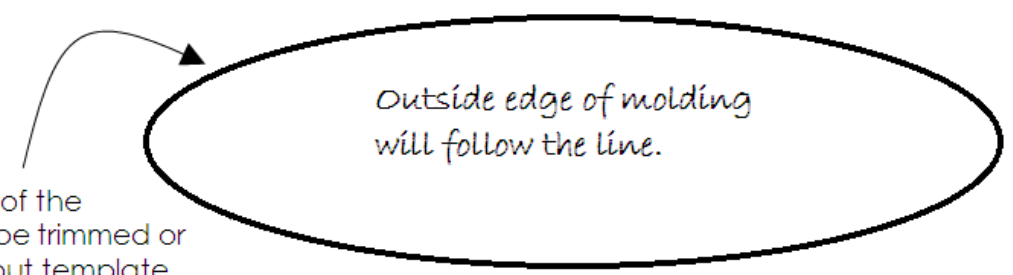

Line tracing of the opening to be trimmed or send a cut-out template

Outside edge of molding will follow the line.