

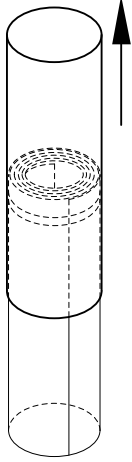

STAND ROLL ON END

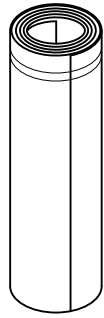

REMOVE SLEEVE



PUT ROLL ON SIDE

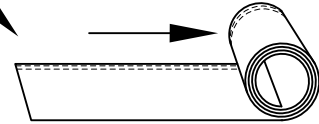
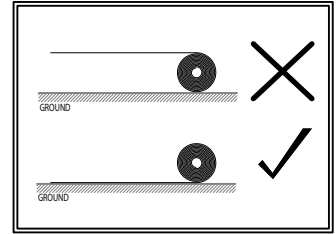
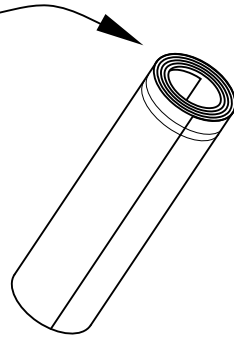

UNROLL RAM BOARD LOGO SIDE UP

**STEP 2**

**STEP 1**

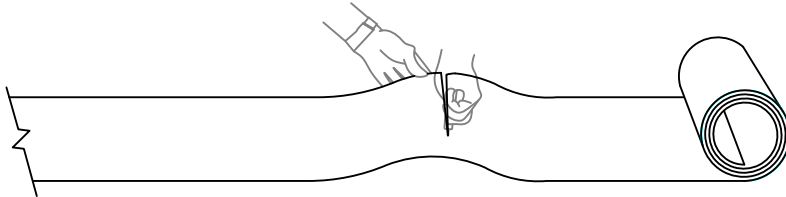

LIFT RAM BOARD UP AWAY FROM FLOOR TO CUT

**STEP 3**

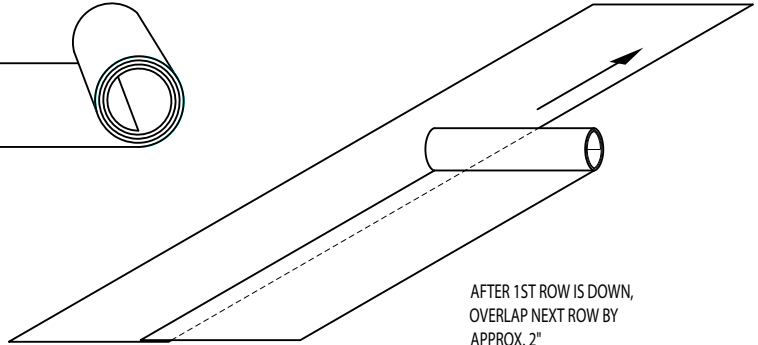

AFTER 1ST ROW IS DOWN, OVERLAP NEXT ROW BY APPROX. 2"

**STEP 4**

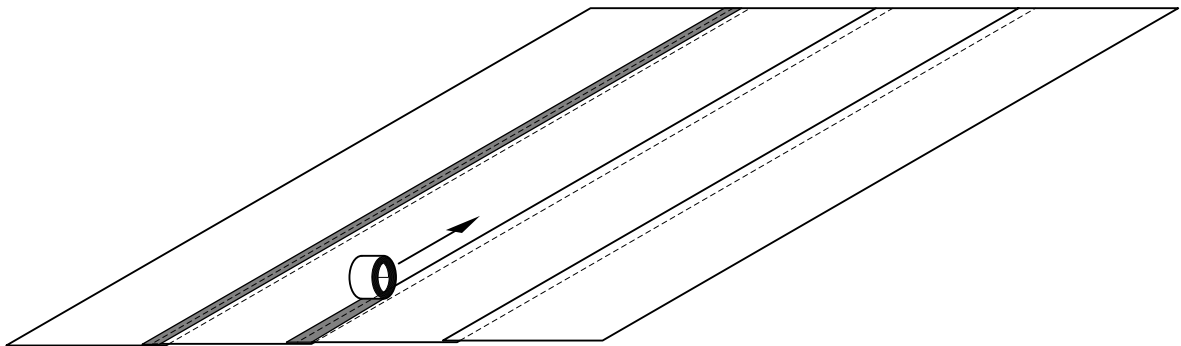

TAPE SEAMS WITH RAM BOARD SEAM TAPE® OR VAPOR-CURE® TAPE

**STEP 5**



PRODUCT

**RAM BOARD® INSTRUCTIONS**

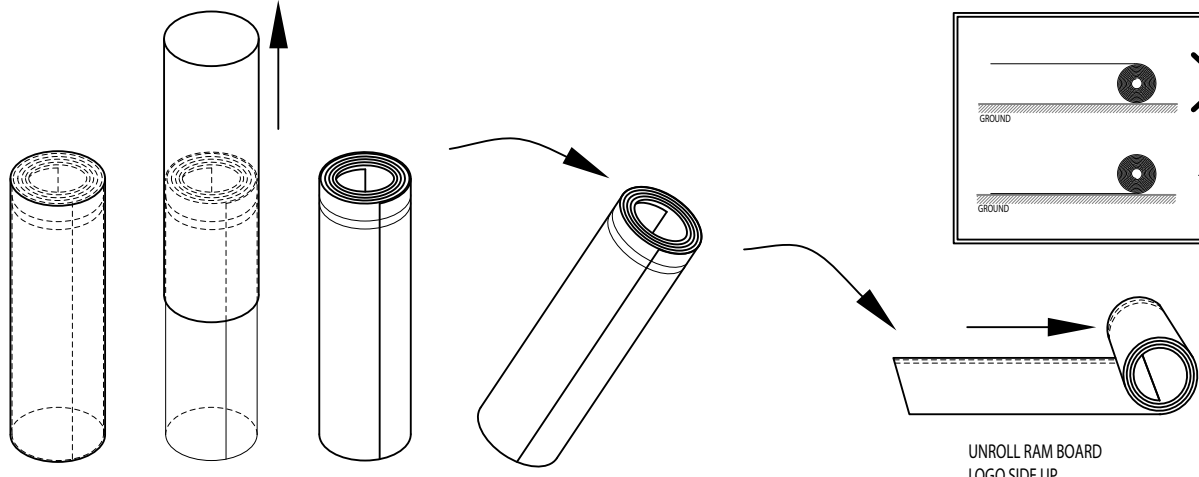

STAND ROLL ON END

REMOVE SLEEVE

PUT ROLL ON SIDE

UNROLL RAM BOARD LOGO SIDE UP

**STEP 1**

**STEP 2**

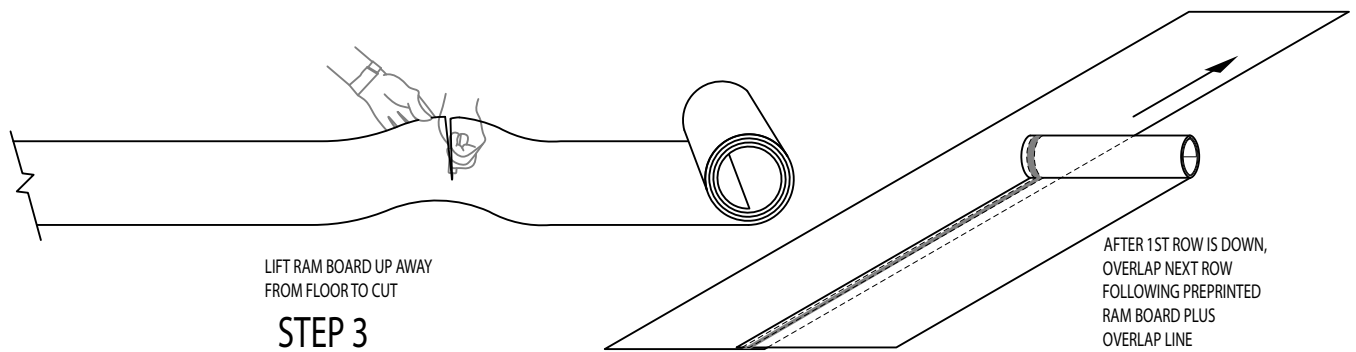

LIFT RAM BOARD UP AWAY FROM FLOOR TO CUT

AFTER 1ST ROW IS DOWN, OVERLAP NEXT ROW FOLLOWING PREPRINTED RAM BOARD PLUS OVERLAP LINE

**STEP 3**

**STEP 4**

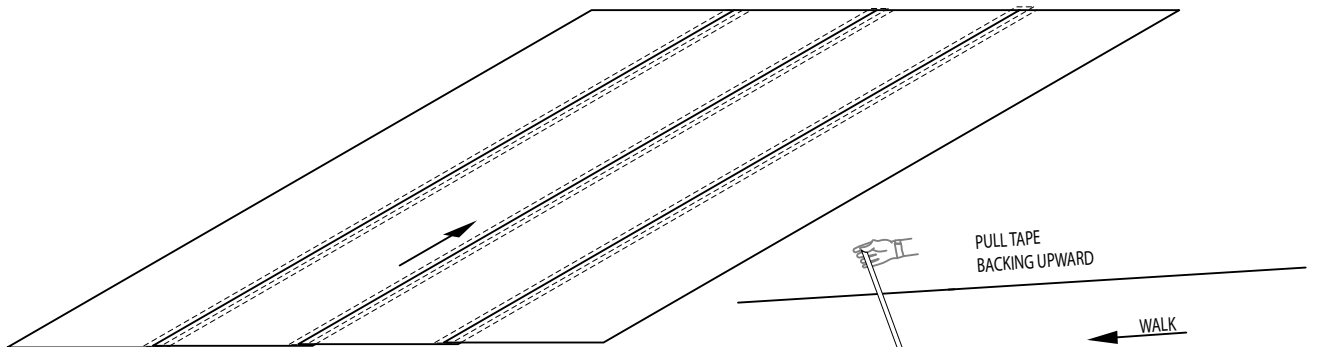

OVERLAP SEAMS FOLLOWING THE PREPRINTED OVERLAP LINE

PULL TAPE BACKING UPWARD

WALK

PULL TAPE BACKING FROM UNDERNEATH BOARD WHILE WALKING BEHIND, STEPPING ON TAPE OVERLAP

**STEP 5**

**STEP 6**



PRODUCT

**RAM BOARD PLUS™ INSTRUCTIONS**

PATENT PENDING

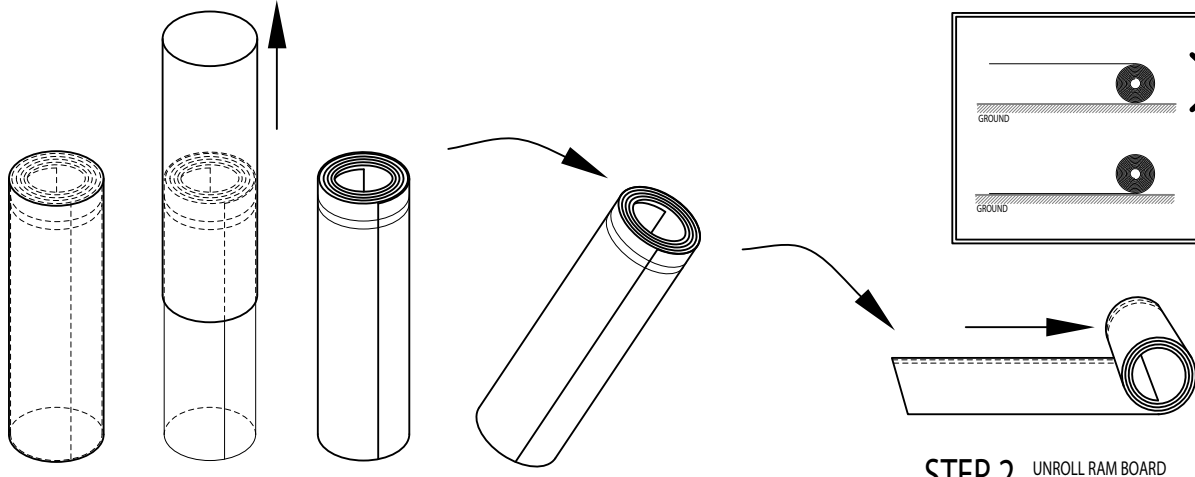

STAND ROLL ON END

REMOVE SLEEVE

PUT ROLL ON SIDE

**STEP 2** UNROLL RAM BOARD LOGO SIDE UP

**STEP 1**

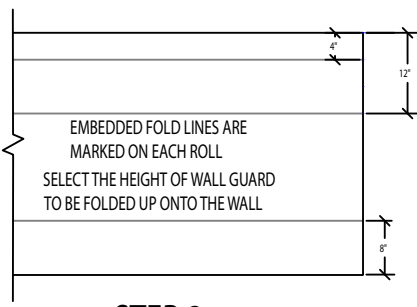

**STEP 3**

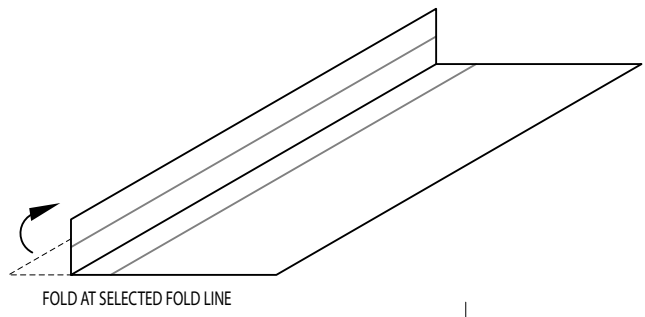

**STEP 4**

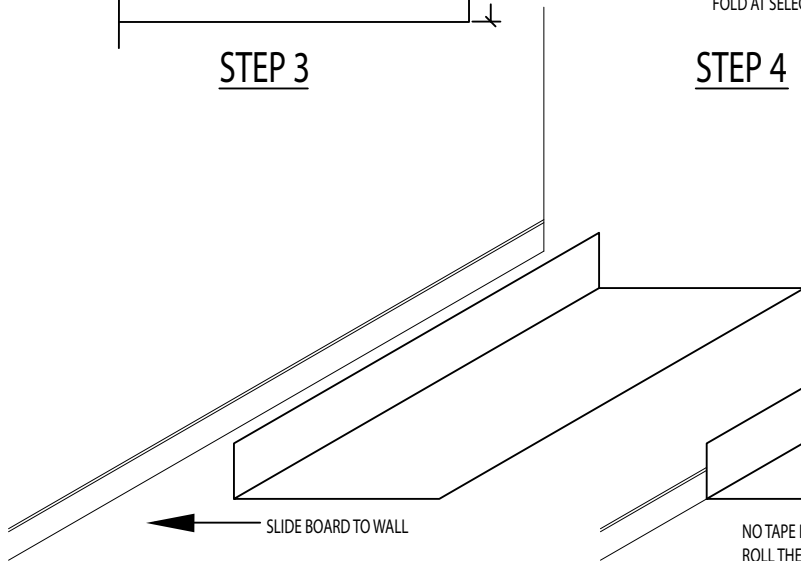

**STEP 5**

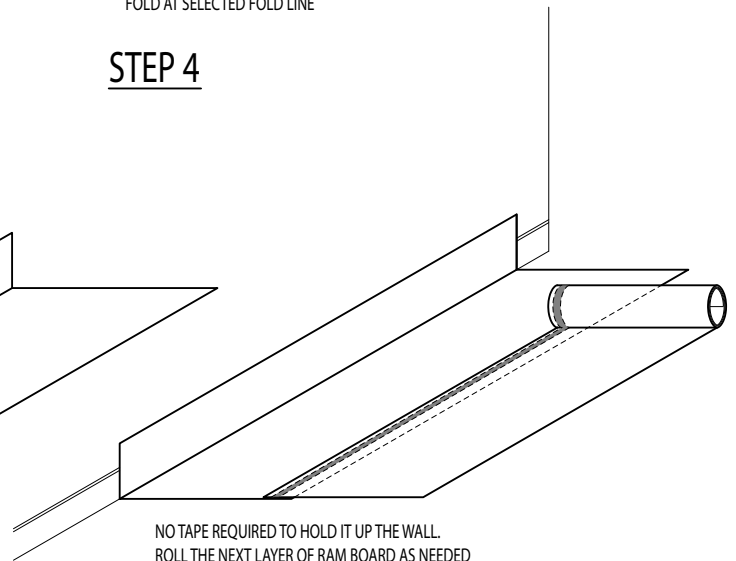

**STEP 6**



PRODUCT

**WALL GUARD® INSTRUCTIONS**

PATENT  
Pat. US 9,365,385  
Pat. US D751,223

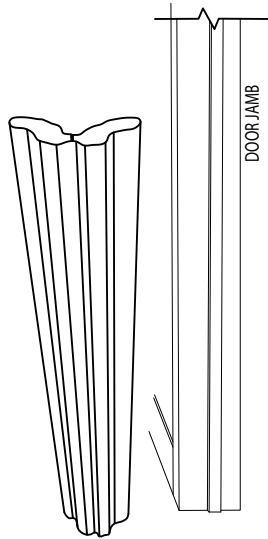

ALIGN RAM JAMB WITH DOOR JAMB

STEP 1

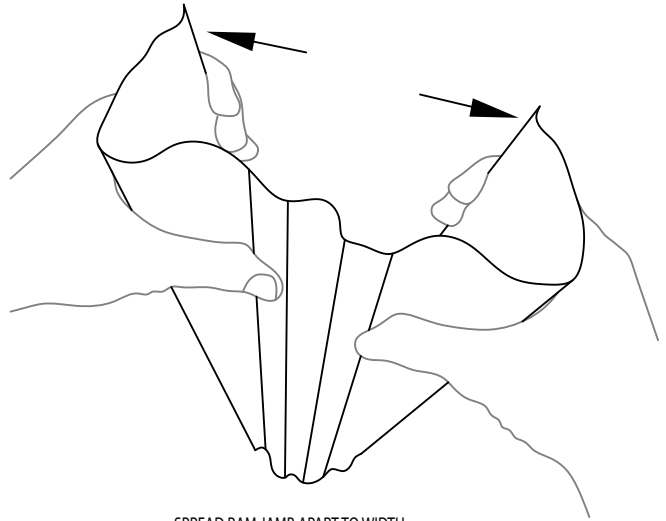

SPREAD RAM JAMB APART TO WIDTH OF DOOR JAMB

STEP 2

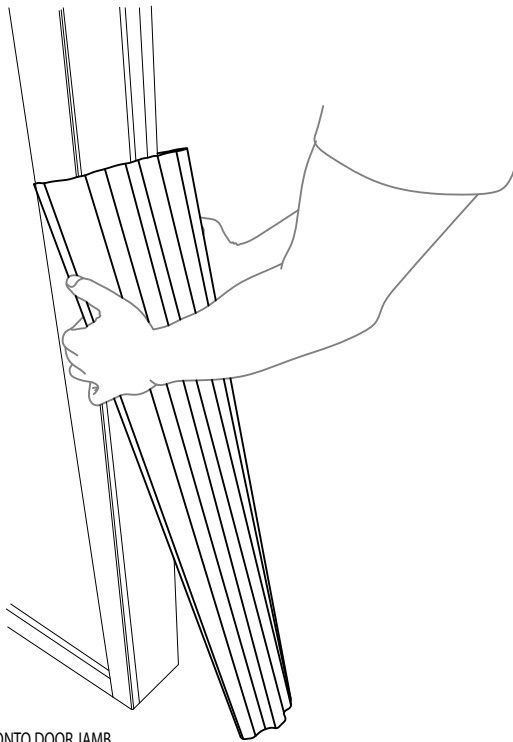

PLACE RAM JAMB ONTO DOOR JAMB

STEP 3

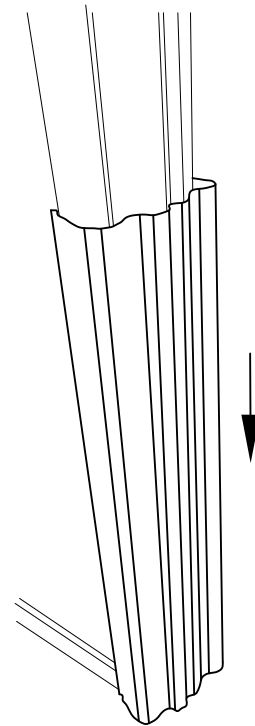

SLIDE RAM JAMB ALONG DOOR JAMB TO FLOOR

STEP 4



PRODUCT

RAM JAMB™ INSTRUCTIONS