

CartStop Super Rail Installation Instructions

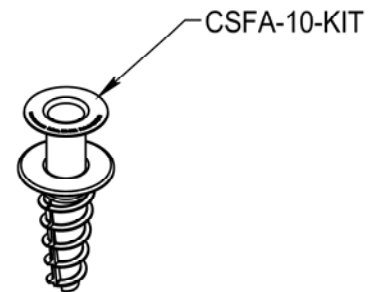
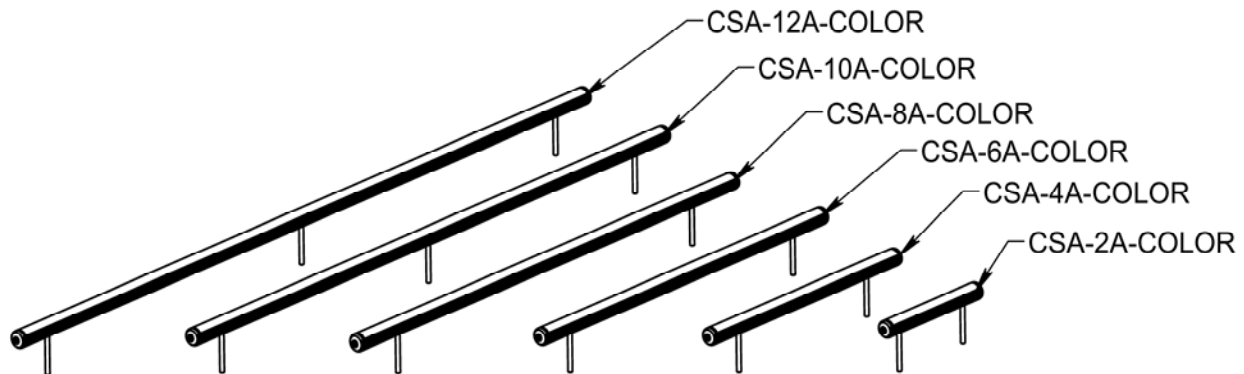

Tools Required:

- Hammer Drill
- 1" Carbide Bit
- Tape Measure
- Pencil
- Allen Wrench Set
- Rubber Mallet
- Straight Edge
- Brush and Dust Pan
- Chalk Line
- Carpenter Square or Framing Square
- Plumb Bob

Step 1: Layout and Positioning

Drop a plumbline from the outer most edge of the case (Figure A.) Make a pencil mark at the plumbline point. Measure 2-1/8" away from the plumbline and snap a chalk line that is 2 1/8" away from the case or wall (Figure B.)

Set CartStopSP over the chalk line in front of the case or fixture that it will protect.

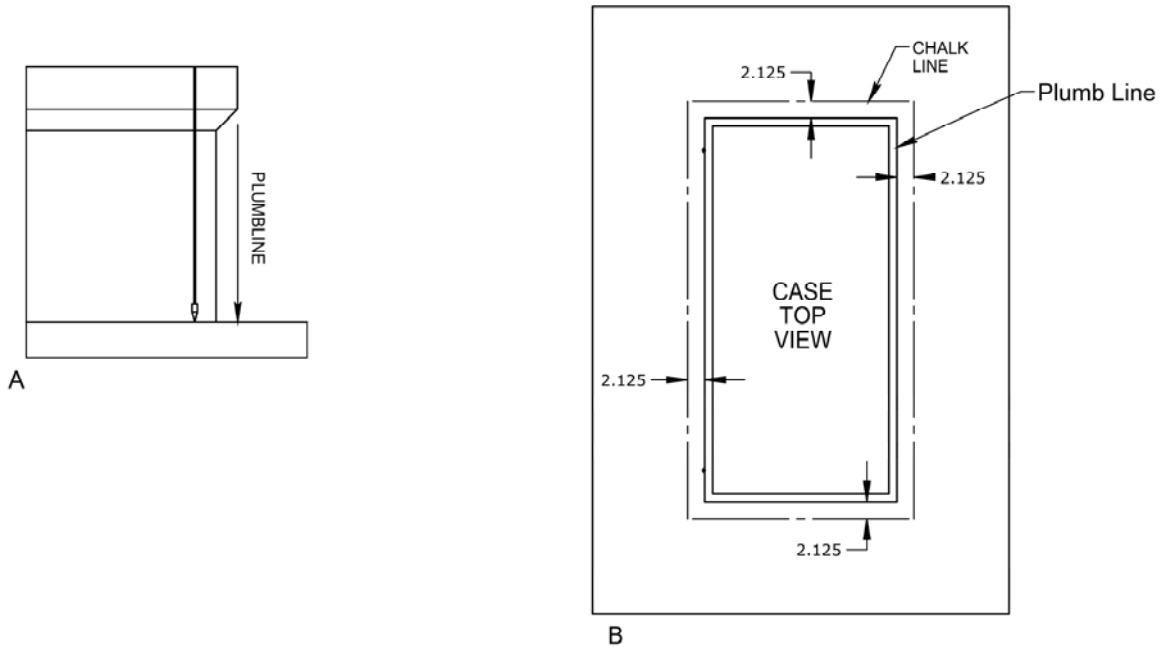

Step 2: Drill Holes for Legs

Position the rail on the floor where it will be installed. With the edge of the rail is 1/2" away from the edge of the corner, trace a circle around each leg onto the floor. Set rail aside.

For each leg, drill a hole that is 1" in diameter and 2 3/4" deep. The holes must be drilled on center. Remove dust and debris from holes.

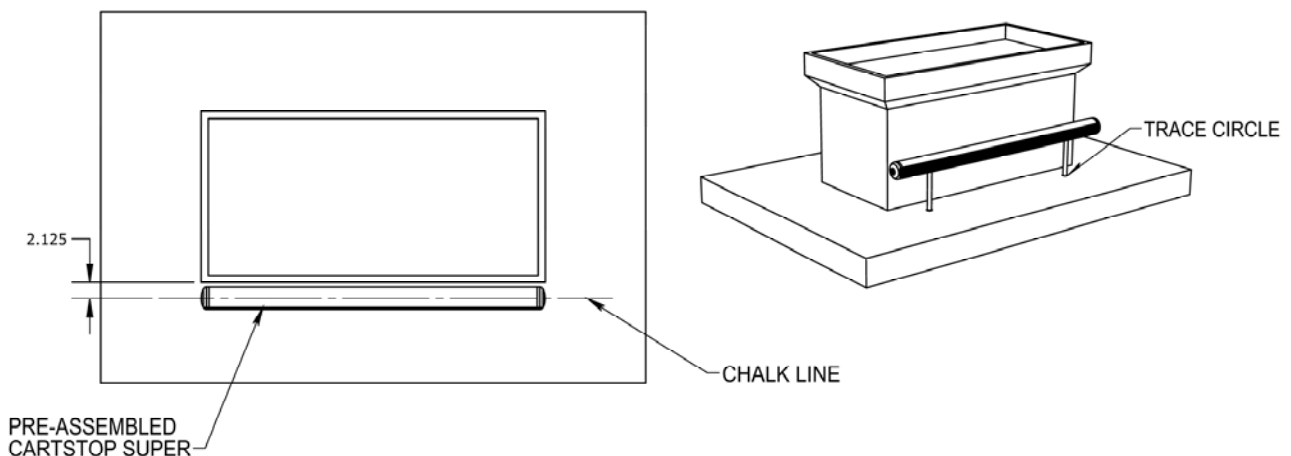

Step 3: Installing the Flange Anchor Sleeves

1. Insert the flange anchor assemblies into the holes.
2. Use a rubber mallet to strike the flange anchors until they are secure in the floor holes.
3. Be sure the top of stainless steel sleeve is fully seated on top of the plastic flange anchor.

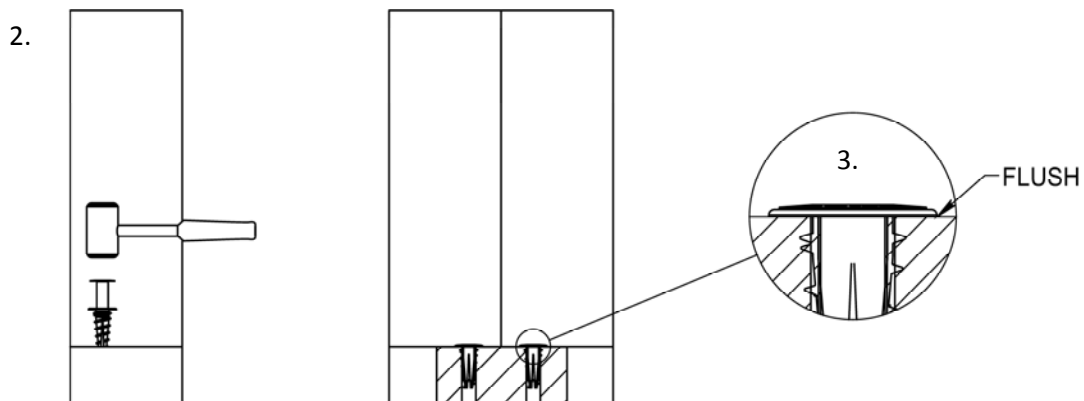
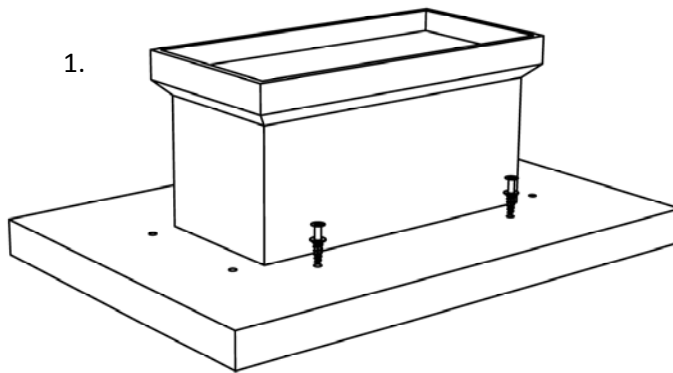

Step 4: Setting Legs into the Floor

Insert the CartStopSP legs into the flange assemblies that have been installed in the floor.

If the holes are off, adjust the legs on the underside of the rail using an Allen key.

Push the rail down so that the legs are fully seated into the flange sleeves.

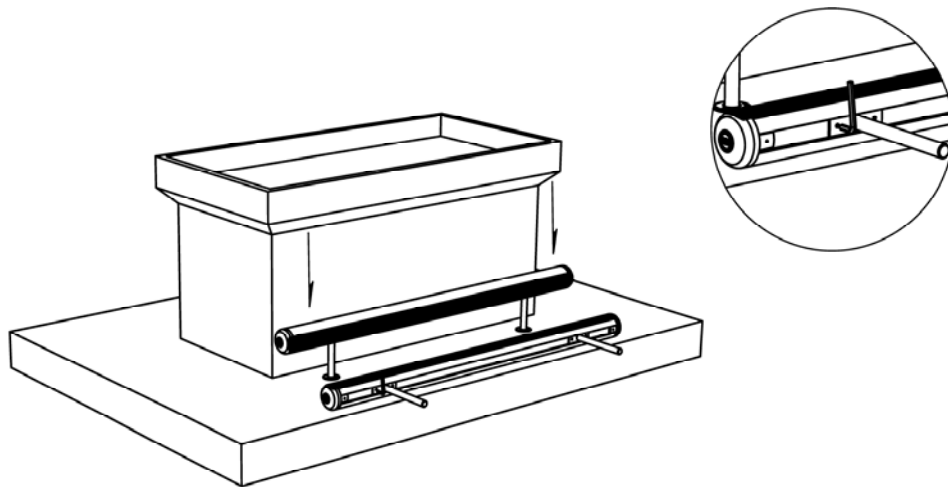

Step 5: Installation is Complete

