

Pro • Tek[®] Industrial & Commercial Impact Protection Systems

Architectural Building Products Since 1945

MD-5 Marine and Industrial Fender

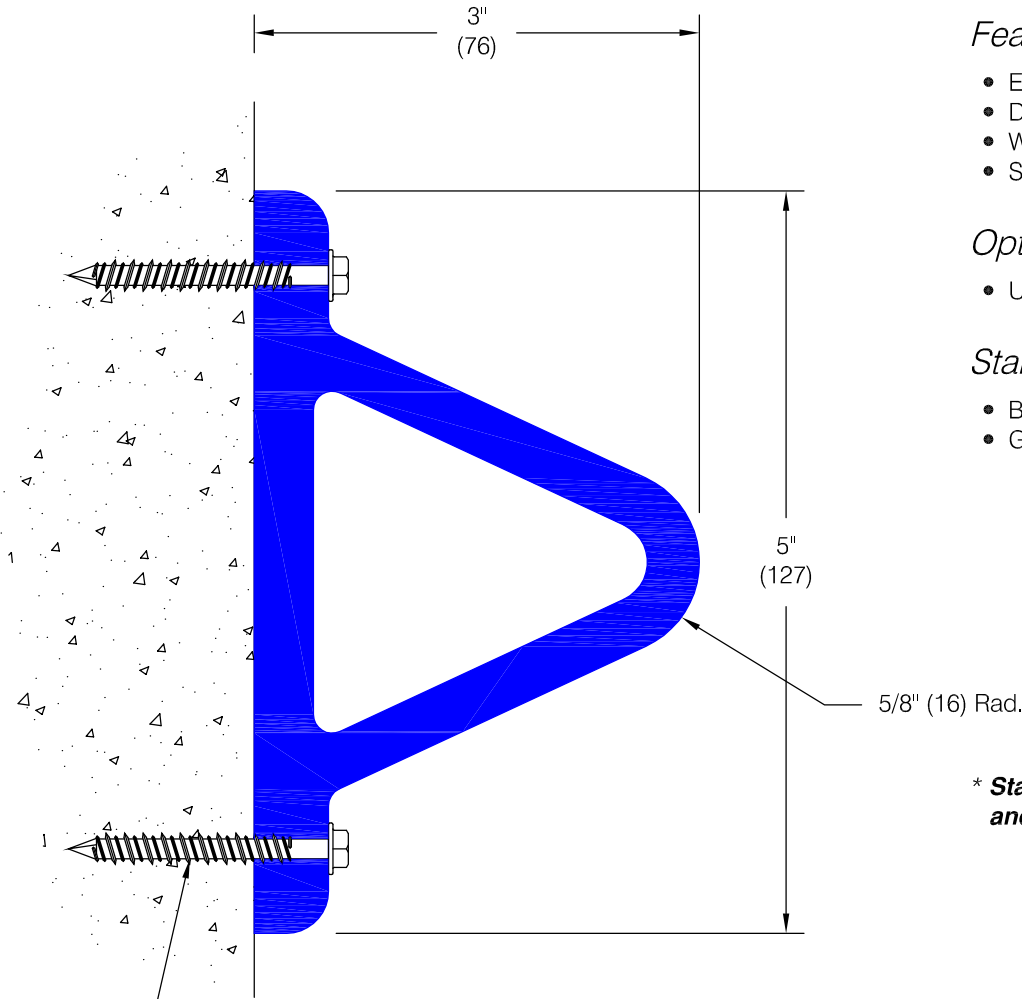

Features:

- Extruded natural rubber to RMA tolerances
- Durometer: 70
- Weight: 3.2 lbs. / lf.
- Stock length: 10'-0" (3048)

Optional Features:

- Urethane end cap (ECMD-5) black only

Standard Colors:

- Black #1
- Gray #5

*** Standard bumper is supplied undrilled and with no mounting hardware.**

Recommended fasteners *

- 16" (406) on center - offset
- Supplied by others
- Suggested concrete hardware:
1/4" (6) x 2" (51) Rawl Tapper™
- Suggested wood hardware:
1/4" (6) x 2" (51) lag screw
- Stainless steel fasteners recommended in marine environments

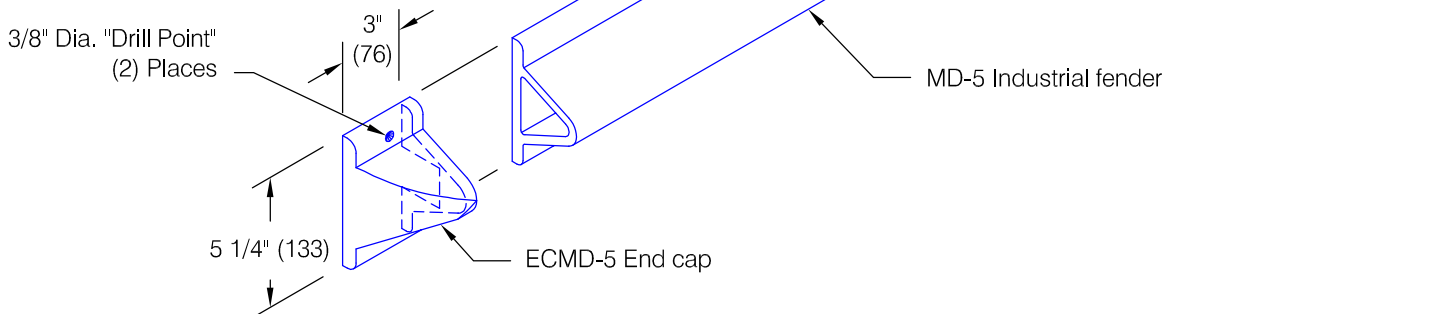

Pawling Corporation reserves the right to discontinue a design or modify an existing design without prior notice

Customer :

Project :

Architect :

Sales Rep :

CD.116.0c