

# Installation Instructions

## JOS-Crnr075

Read all installation instructions before installing product. If retrofitting a parking area, always use cones, barrels or other means to secure the area and alert motorists. Confirm installation height meets local building codes, if any apply.

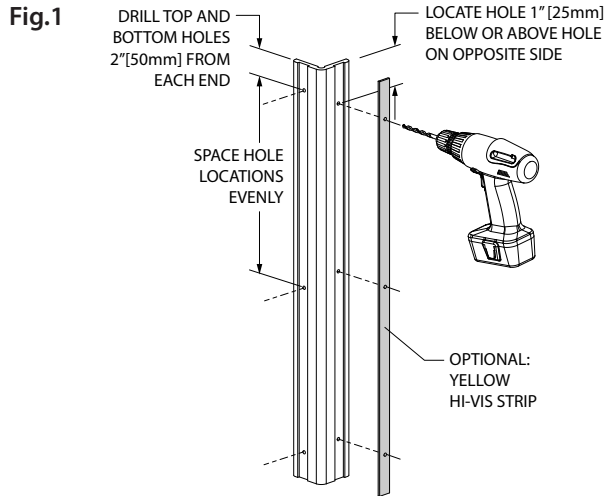

Figure 1

1. Drill hardware hole locations centered in the recessed grooved channels on both wings of the corner guard using a 5/16" [8mm] drill bit. On one wing, drill the top and bottom holes roughly 2" [50mm] from each edge, with the third hole centered on the length of the corner guard. Repeat on opposite wing, remembering to stagger the hole locations 1" [25mm] above or below the holes on the opposite side.

NOTE: If corner guard uses the optional yellow high visibility strip, drill the corresponding hole locations centered on the strip. A counter sink may be required to get screw head flush with yellow strip.

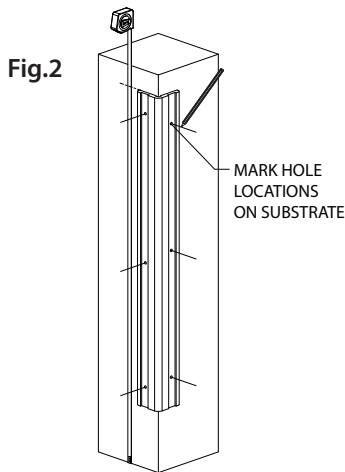
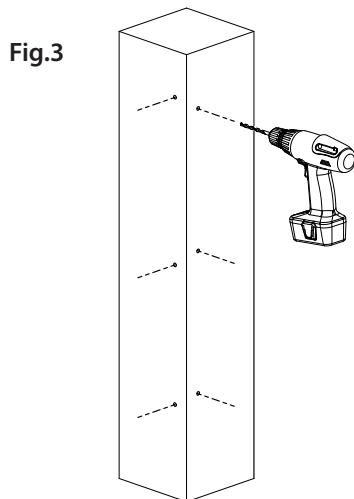

Figure 2

2. Position corner guard at appropriate height on the wall. Mark the drilled holes from each wing of the corner guard onto the substrate it is being installed on. When finished, remove corner guard from corner.

Figure 3

3. Drill the marked hole locations using a 5/16" [8mm] drill bit. Make sure holes are clean and free of debris and dust, blow out holes with compressed air if required.



IPC.1608/REV.1

# Installation Instructions

## JOS-Crn075

Fig.4

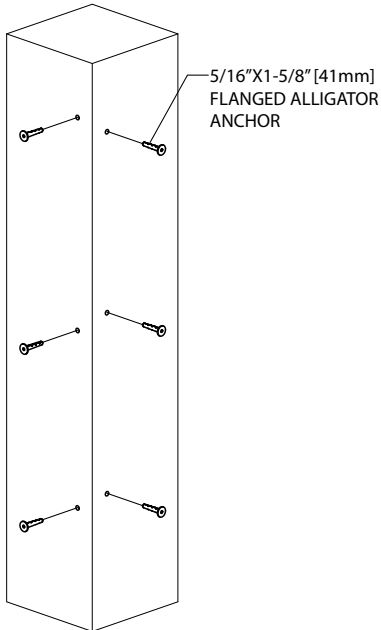

Figure 4

4. Insert supplied 5/16" x 1-5/8" [41mm] flanged alligator anchors (found in hardware pack JK182) into the drilled holes.

Figure5

5. Return corner guard to the proper position on the corner. Using supplied #14 x 1-3/4" Flat Head self tapping fasteners (found in hardware pack JK182), secure the corner guard to the in place. Ensure fastener head is flush, or slightly embedded into the surface of the corner guard.
6. If installing corner guard with yellow high visibility strips. Position both the corner guard and yellow strip on the wall prior to securing with #14 Fasteners. Ensure fastener head is flush, or slightly embedded into the surface of the corner guard.

(See Fig.5a)

Fig.5

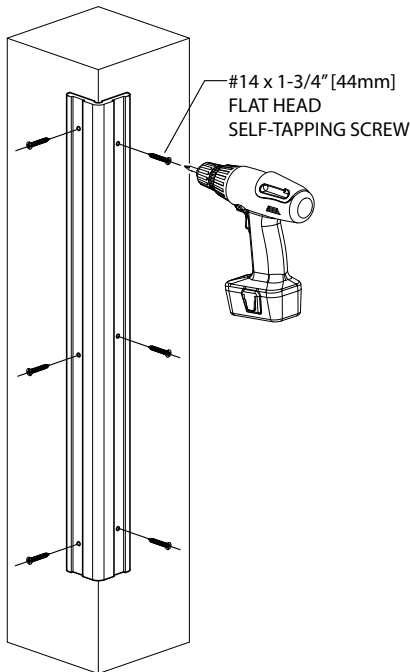

Fig.5a

