

Installation Instructions

Joint System: 807 - A01/ A02

Note: Verify that the structural gap is in conformance with submittal data before beginning installation. If this is a Fire Rated Assembly, install the fire barrier before the Architectural Joint System. Refer to the fire barrier instructions for specific system installation.

FIG. 1

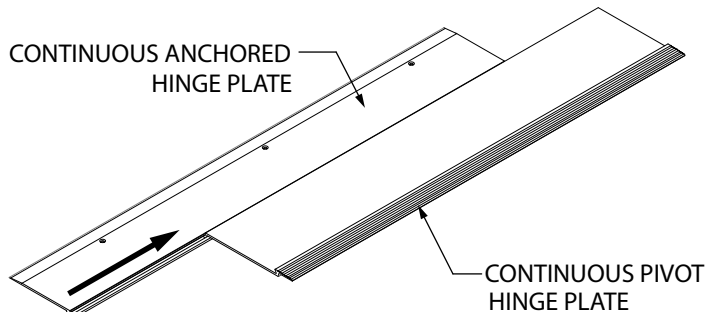

FIG. 1a (FLOOR TO FLOOR CONDITION)

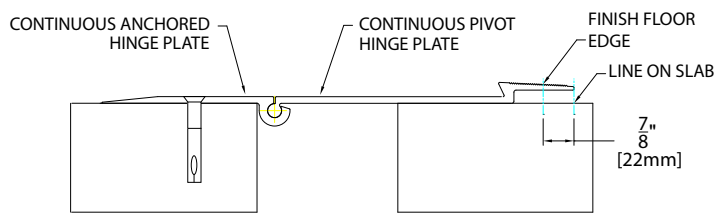
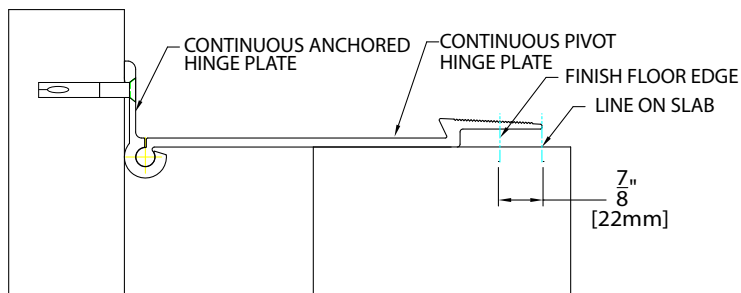

FIG. 1b (FLOOR TO WALL CONDITION)



1. Install the architectural joint system on a level finished floor. This may require adding leveling compound on top of the substrate to provide a smooth mounting surface.

See Figure 1

2. Cut the aluminum plates to the desired length. Slide the pivoting half of the hinge plate into the anchored half of the hinge plate.
3. Place the plate assembly over the structural gap.
 - 3a. For floor to floor (A01) condition, keep the hinge side of the plate tight against one edge of the joint. **See Figure 1a.**
 - 3b. For floor to wall (A02) condition, short leg (pre-drilled hole side) should be placed firmly against the finished wall. Align level with the finished floor. **See Figure 1b.**
4. Mark the pre-drilled hole locations on the substrate.
5. Using the end of the cover mark a line on the slab. Measure 7/8" (22mm) towards the structural gap. This is the end of the finished floor. **See Figure 1a and 1b.**
6. Remove the plate assembly.

IPC.893/REV.1

Installation Instructions

Joint System: 807 - A01/ A02

Note: Verify that the structural gap is in conformance with submittal data before beginning installation. If this is a Fire Rated Assembly, install the fire barrier before the Architectural Joint System. Refer to the fire barrier instructions for specific system installation.

FIG. 2

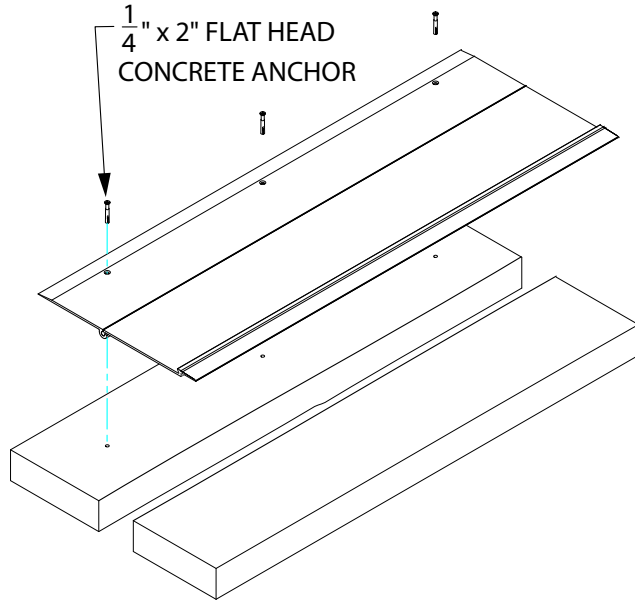

Figure 2

7. Drill all marked holes on the substrate using a 1/4" (6 mm) drill bit and drill 2 1/4" (58mm) deep. Insert concrete sleeve anchors.
8. Return the plates into position over the drilled hole locations and secure in place with one flat head screw for each anchor.

Figure 3 & 3a.

9. Clean the exposed surfaces with a non-solvent cleaner, such as 409, as required.
10. Complete installation with appropriate flooring.

FIG. 3

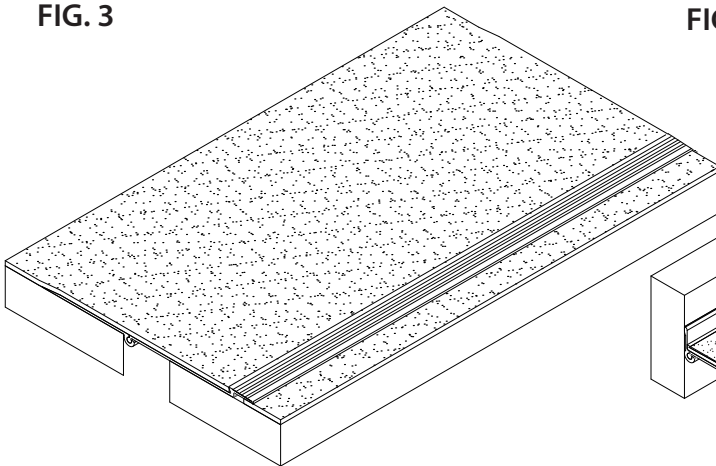

FIG. 3a

